

NOTES: (UNLESS OTHERWISE SPECIFIED):

BOARD HOUSE - SEE SHEET 3 FOR PWB RAIL DIMENSIONS  
 ASSEMBLY HOUSE - MAX SCREW TORQUE 1.5 IN-LBS

REVISION				
ZONE	REV	DESCRIPTION	DATE	
	3	PROTOTYPE RELEASE	3-8-05	
	4	PROTOTYPE UPDATE	7-26-05	

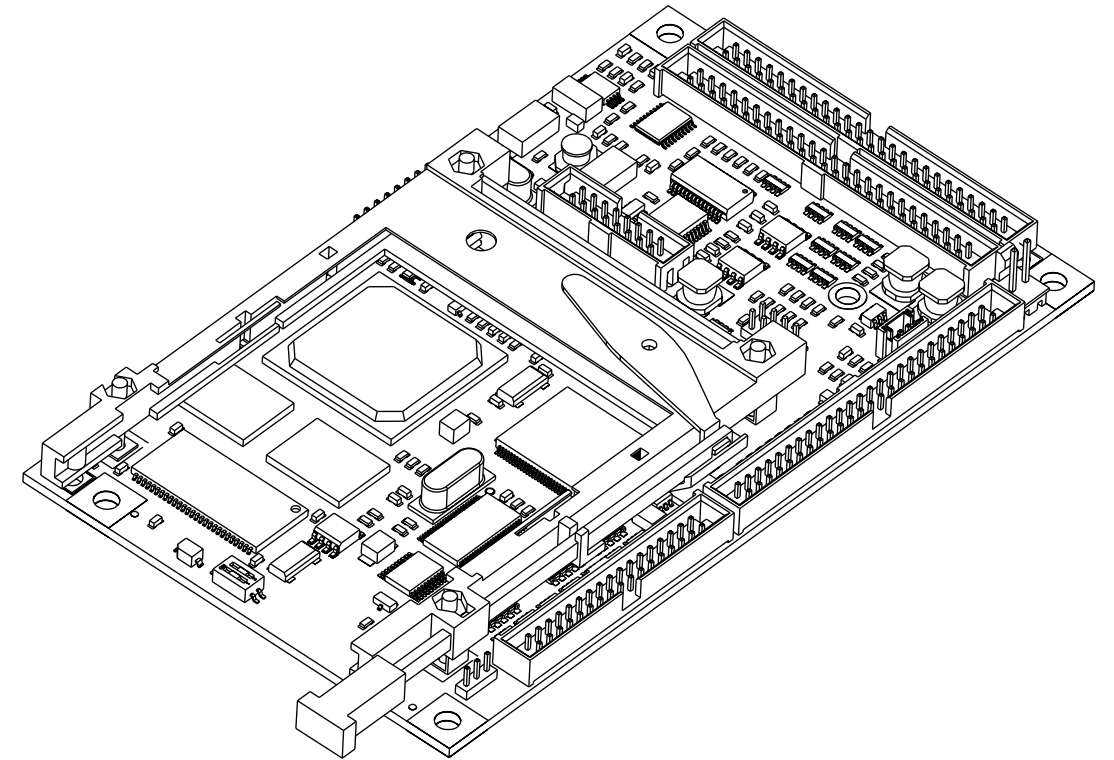
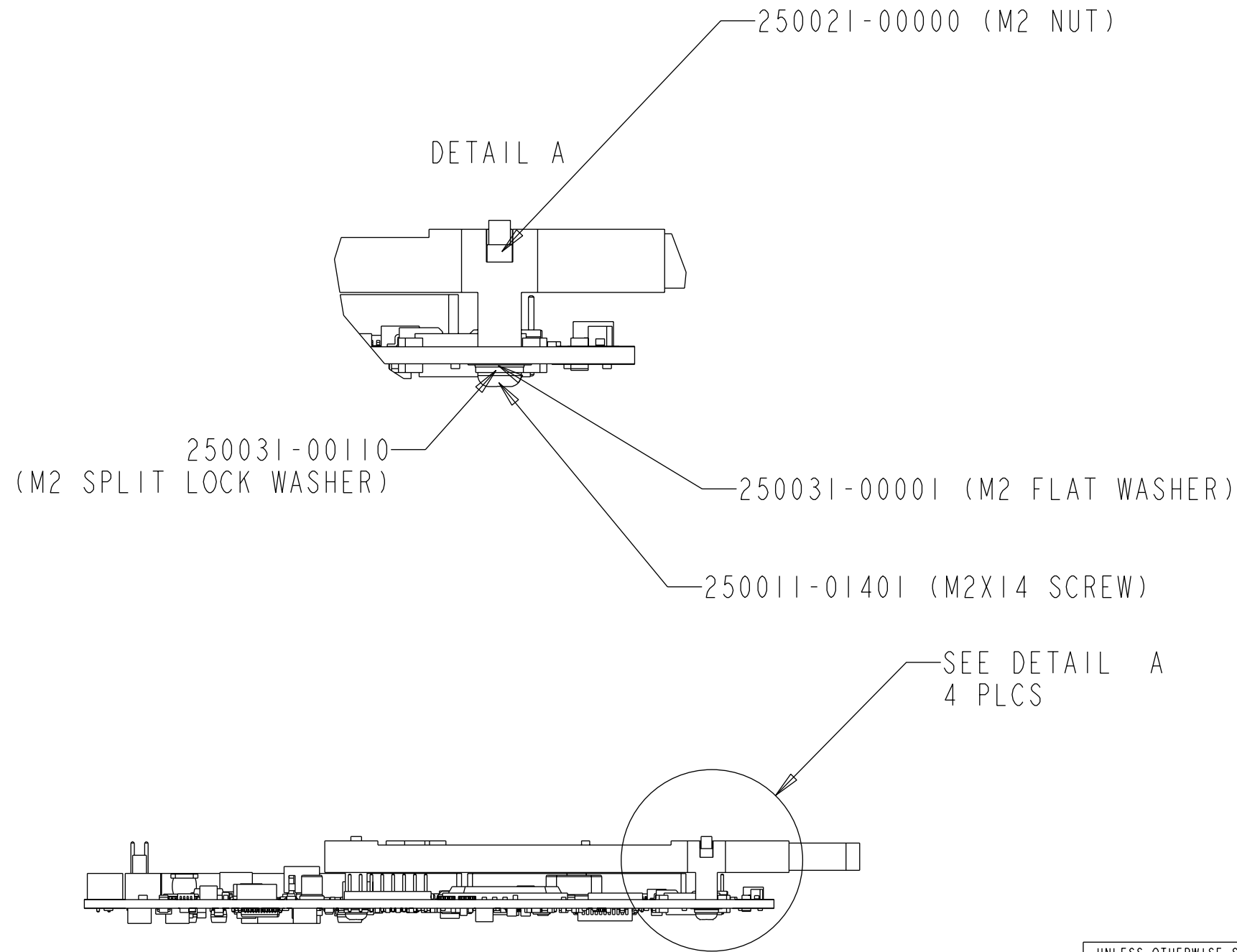

UNLESS OTHERWISE SPECIFIED  
 DIMENSIONS ARE IN INCHES  
 TOLERANCES ARE:  
 DECIMALS  
 .XX ± .01  
 .XXX ± .005  
 ✓ RMS ALL MACHINED SURFACES  
 BREAK ALL SHARP EDGES  
 AND CORNERS, REMOVE BURRS.

MATERIAL

FINISH

THIS DOCUMENT CONTAINS INFORMATION  
 PROPRIETARY TO ADS AND  
 SHALL NOT BE USED FOR ENGINEERING  
 DESIGN, PROCUREMENT OR MANUFACTURER  
 IN WHOLE OR IN PART WITHOUT THE  
 CONSENT OF ADS

MECHANICAL ENGINEER  
 M. BLATTAU 11-2-04

**ADS**

<b>APPLIED DATA SYSTEMS</b> 10260 Old Columbia Rd. Columbia, Maryland 21046 USA		
TITLE <b>BITSY Xb</b> MECHANICAL DETAIL		
SIZE B	DWG. NO. 630118-0000	REV 4
SCALE: 1.000	DO NOT SCALE DRAWING	SHEET 1 OF 3

D  
C  
B  
A

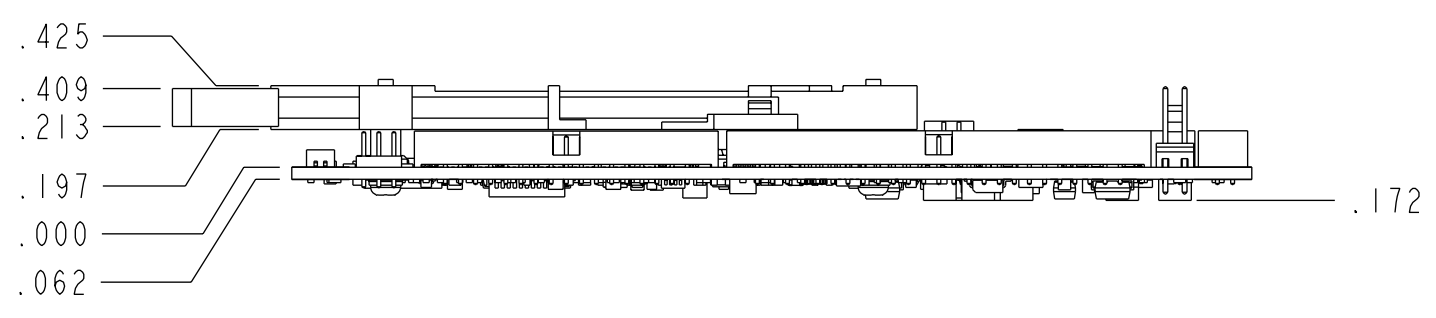
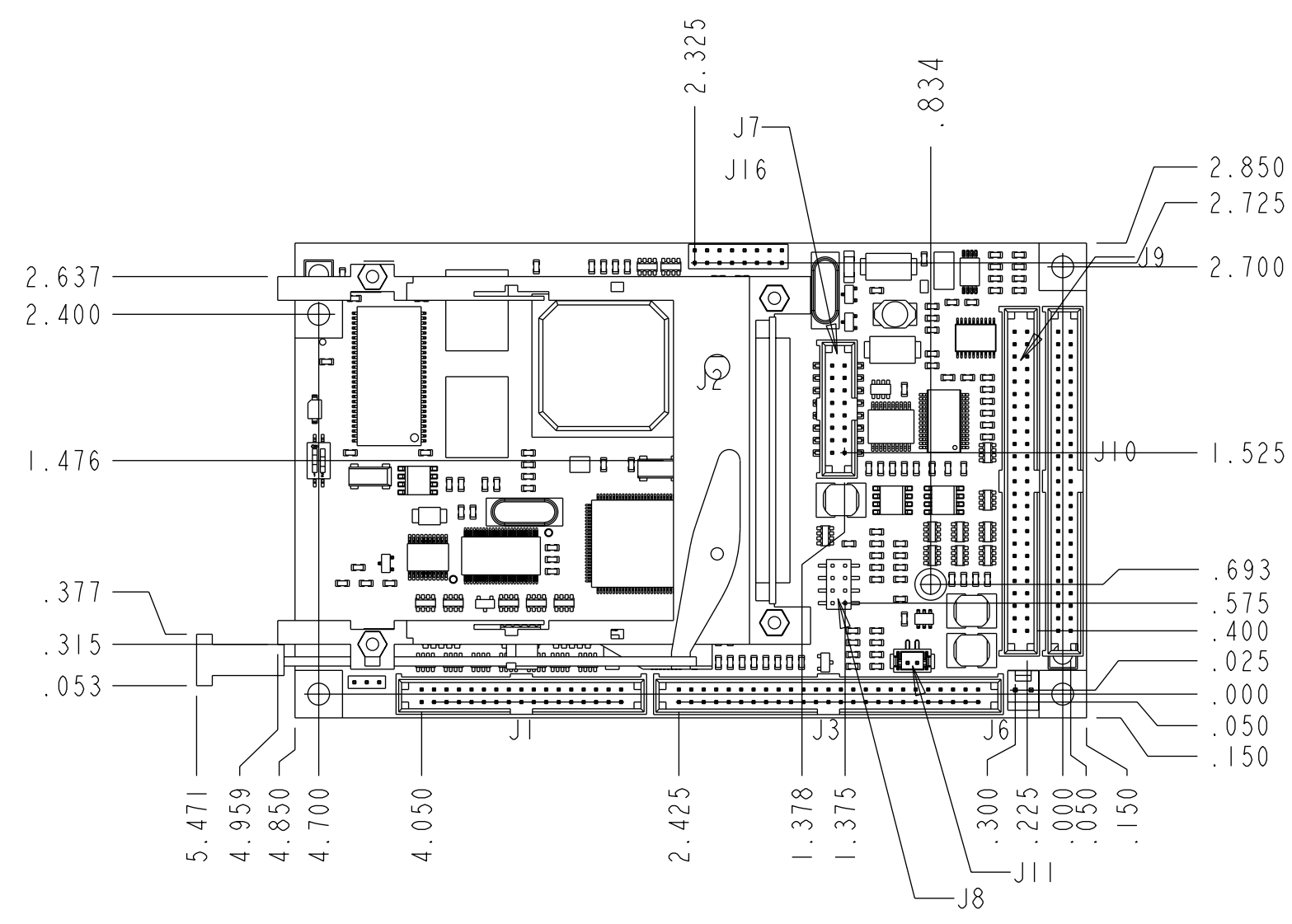
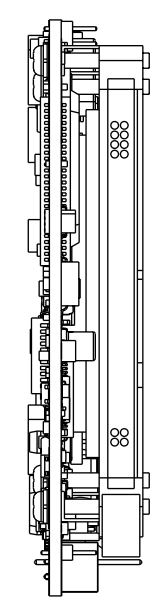

4

3

2

1

4

3

2

1

SIZE B	DWG. NO. 630118-0000	REV 4
SCALE: 1.000	DO NOT SCALE DRAWING	SHEET 2 OF 3

RAIL DIMENSIONAL DRAWING

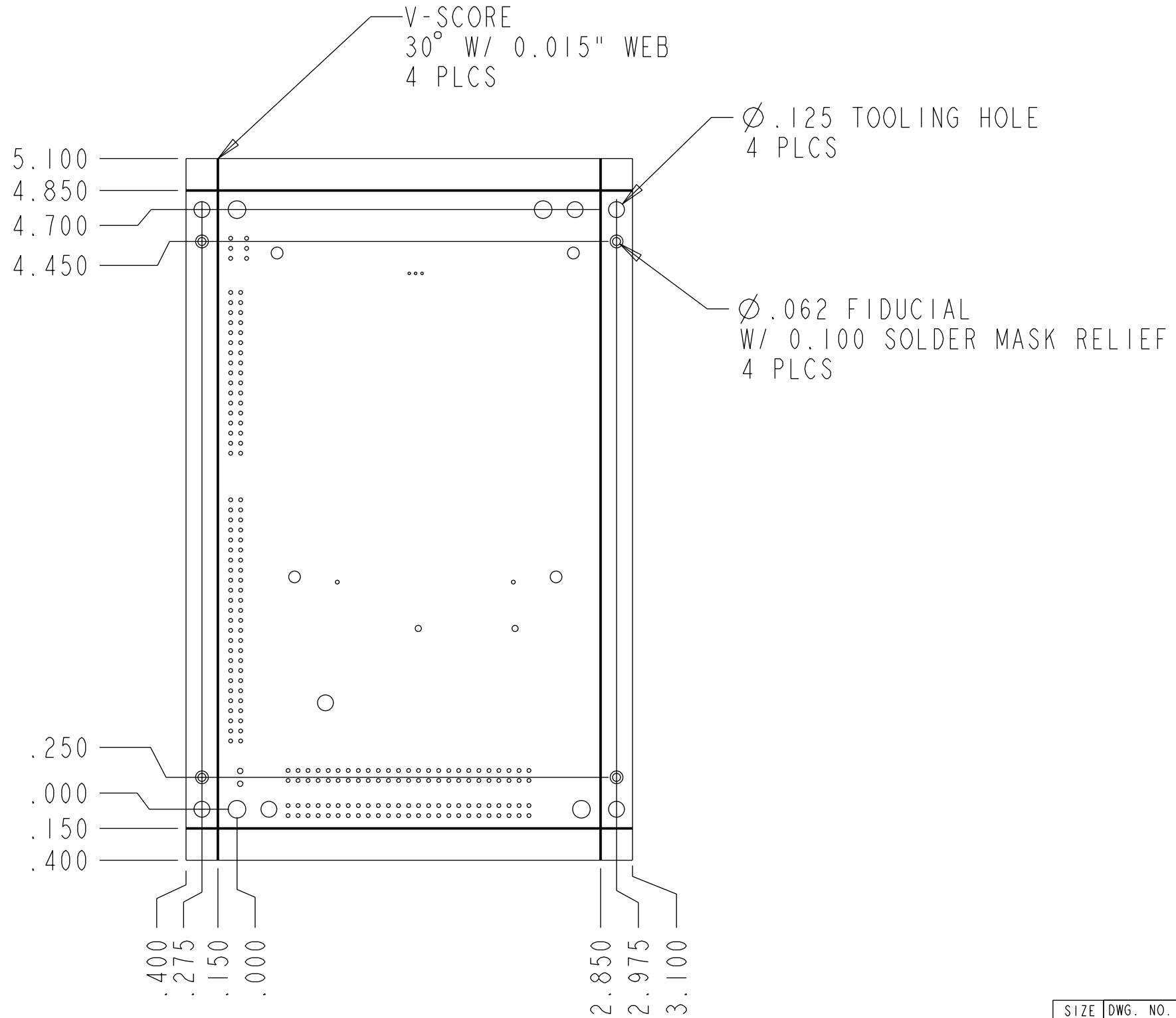

SIZE B	DWG. NO. 630118-0000	REV 4
SCALE: 1.000	DO NOT SCALE DRAWING	SHEET 3 OF 3